



Features

- This series is UL listed under the Recognized Component Index, file number E142814
- The plastic material used carries Underwriters Laboratory flammability recognition 94V-0
- Surge overload ratings to 30 amperes
- Ideal for printed circuit board application
- High temperature soldering guaranteed 260 °C /5 seconds at 5 lbs (2.3kg) tension

Mechanical Data

Case: Molded plastic
 Terminals: Plated leads solderable per MIL-STD-202, Method 208
 Polarity: Marked on body
 Mounting Position: Any
 Weight: 0.04 ounce, 0.34 grams (approx)

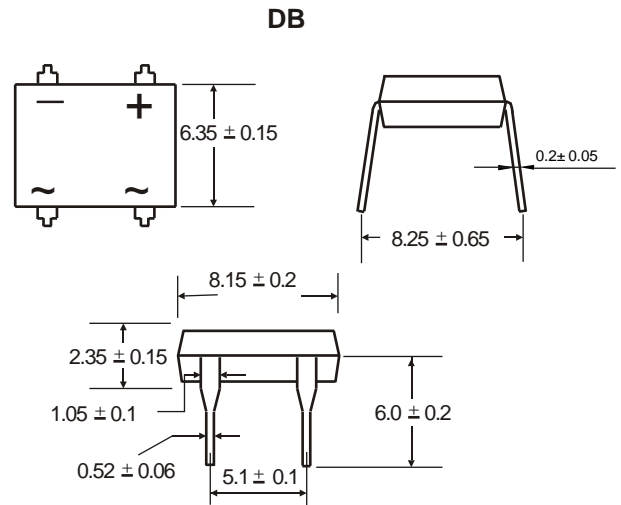

Dimensions in millimeters (1mm =0.0394")

Maximum Ratings & Thermal Characteristics

Rating at 25°C ambient temperature unless otherwise specified, Resistive or Inductive load, 60 Hz.
 For Capacitive load derate current by 20%.

Parameter	Symbol	DB101	DB102	DB103	DB104	DB105	DB106	DB107	Unit
Maximum repetitive peak reverse voltage	VRRM	50	100	200	400	600	800	1000	V
Maximum RMS bridge input voltage	VRMS	35	70	140	280	420	560	700	V
Maximum DC blocking voltage	VDC	50	100	200	400	600	800	1000	V
Maximum average forward rectified output current at TA=40°C	IF(AV)	1.0							A
Peak forward surge current single sine-wave superimposed on rated load (JEDEC Method)	IFSM	30							A
Rating for fusing (t<8.3ms)	I ² t	10							A ² sec
Typical thermal resistance per element (1)	ReJA	110							°C / W
Typical junction capacitance per element (2)	Cj	25.0							pF
Operating junction and storage temperature range	TJ, TSTG	-55 to + 150							°C

Electrical Characteristics

Rating at 25°C ambient temperature unless otherwise specified. Resistive or Inductive load, 60Hz.
 For Capacitive load derate by 20 %.

Parameter	Symbol	DB101	DB102	DB103	DB104	DB105	DB106	DB107	Unit
Maximum instantaneous forward voltage drop per leg at 1.0A	VF	1.1							V
Maximum DC reverse current at rated DC blocking voltage per element	IR	10 500							μA

Notes: (1)Thermal resistance from Junction to Ambient on P.C.board mounting.
 (2)Measured at 2.0MHz and applied reverse voltage of 4.0 volts.



Rating and Characteristic Curves ($T_A=25^\circ\text{C}$ Unless otherwise noted)

Fig. 1 Derating Curve for Output Rectified Current

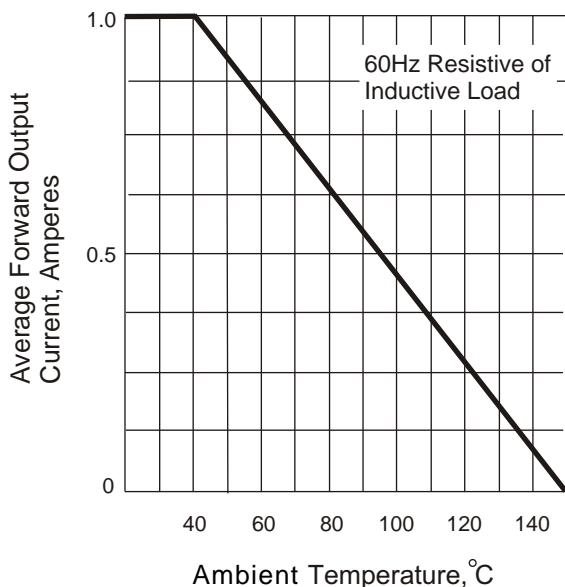

Fig. 2 Maximum Non-repetitive Peak Forward Surge Current

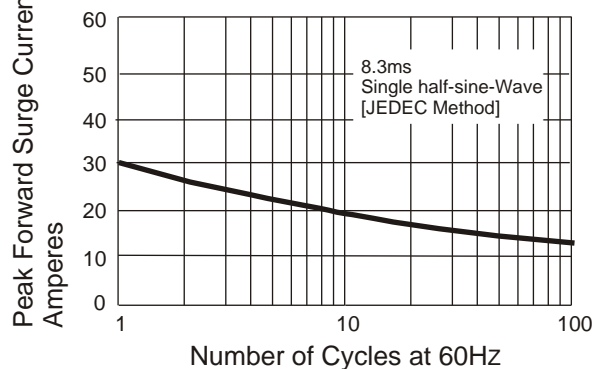

Fig. 3 Typical Instantaneous Forward Characteristics

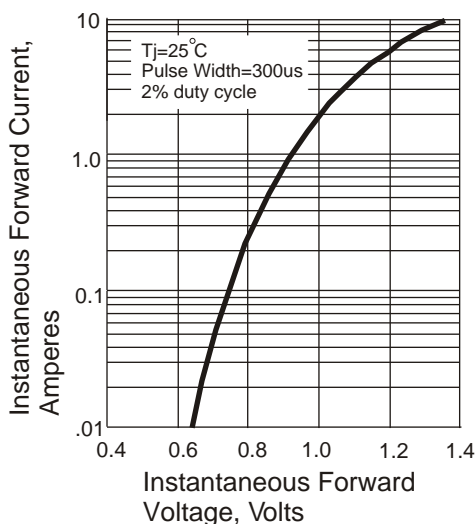

Fig. 4 Typical Revers Characteristics

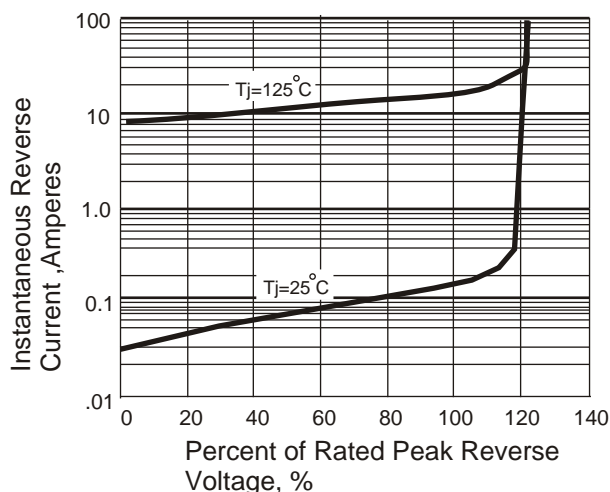

Fig. 5 Typical Junction Capacitance

